

**SC50** wheeled shipping case

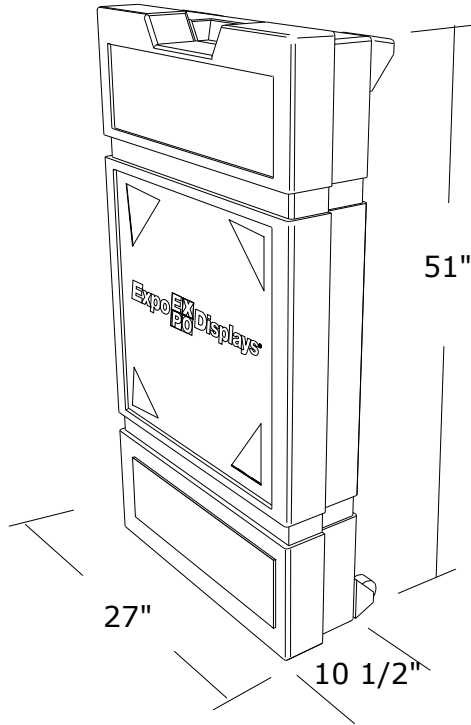

**SC60** wheeled shipping tub

\*Because ExpoDisplays does not recommend shipping components with a non-fabric finish in the SC60 tub, ExpoDisplays will not do so without written removal of liability to do so.

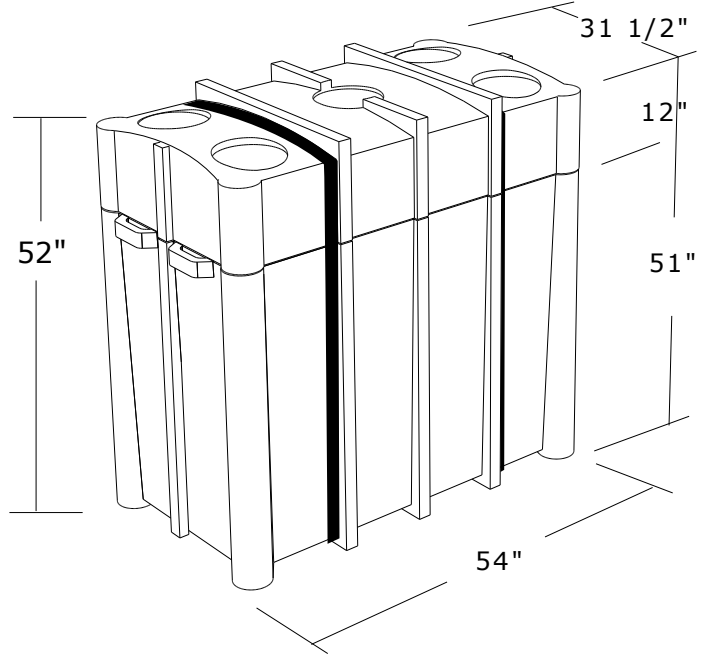

**CRATE** Custom Wooden Shipping Crate

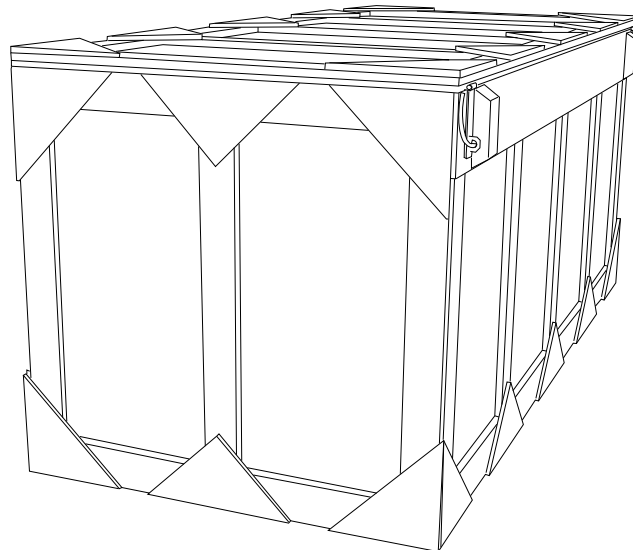

**WEIGHTS**

SC50	22 lbs.
SC60	91 lbs.

**INSIDE MEASUREMENTS**

	length	width	height
SC50	48"	26"	7 1/2"
SC60	48"	28.5"	48"